

Comercializadora de Maquinados y Herramientas



Antecedentes

COMERCIALIZADORA CARVAS es una empresa que ha permanecido en el mercado por más de diez años, brindando a la industria: *diseño y fabricación de troqueles, moldes de extrusión, inyección dispositivos de ensamble y control, diseño industrial entre otros, así como servicios de mantenimiento preventivo y correctivo a diferentes herramientas.*





Misión

Brindar siempre una mejora continua en: ingeniería e innovación tecnológica, aplicada a cada producto y servicio requerido por nuestros clientes.



Visión

Buscamos la expansión de nuestra cartera de clientes, brindándoles seguridad y confianza en cada uno de los productos y servicios que ofrecemos, asimismo, que COMERCIALIZADORA CARVAS sea una empresa económicamente sustentable a lo largo del tiempo.

POLITICA DE CALIDAD

En **COMERCIALIZADORA CARVAS** estamos comprometidos con la satisfacción de nuestros clientes, es por ello que buscamos cumplir cada uno de sus requerimientos con la más alta calidad, apegándonos siempre a procesos, normas y criterios establecidos como valor de referencia.



Productos y servicios

- Fabricación de troqueles.
- Fabricación de dispositivos de ensamble y control.
- Erosión (corte por hilo)
- Erosión (penetración)
- Maquila de troquelado hasta 60 toneladas.
- Maquila de piezas pequeñas (tornos automáticos)
- Maquila de maquinados de precisión línea (CNC tornos)
- Fabricación de dados de extrusión de plástico (perfiles)
- Medios de control (GO-NOGO).
- Fabricación de moldes de inyección para poliuretano y plástico
- Maquinados en general
- Aplicación de soldadura de argón (gas tungsteno, arco eléctrico).
- Contamos con soldadura laser para la reconstrucción de piezas y reparación de moldes



ALGUNOS DE NUESTROS CLIENTES



Erosión de piezas, hilo y penetración

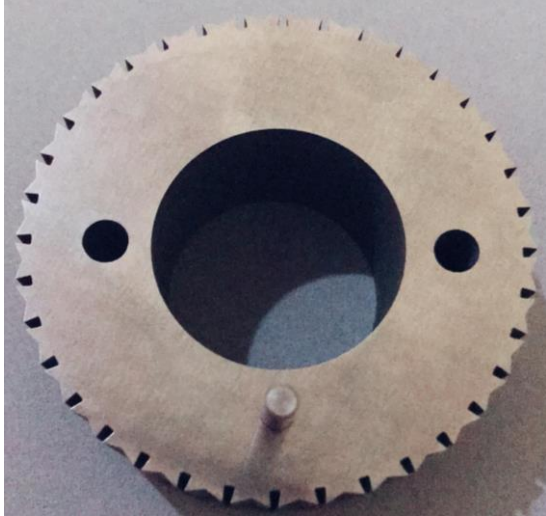

Engrane de precisión

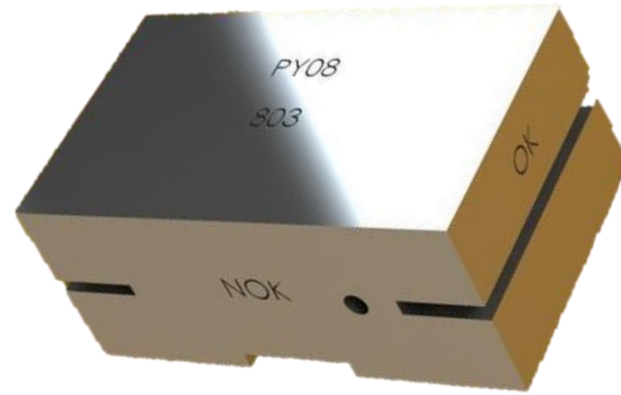

Gage



Boquilla



Lunas

Maquila para algunos de nuestros clientes



Soporte U

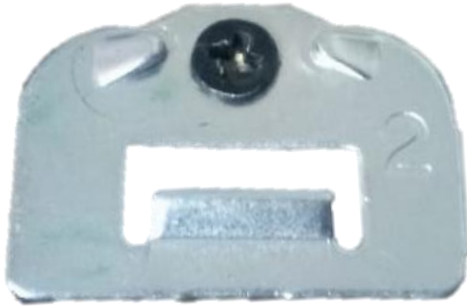

Ficha Metálica



Seguros omega



Soporte U3



Placa metálica



Brida



Yo-yo



A



Tapas para sellos
mecánicos

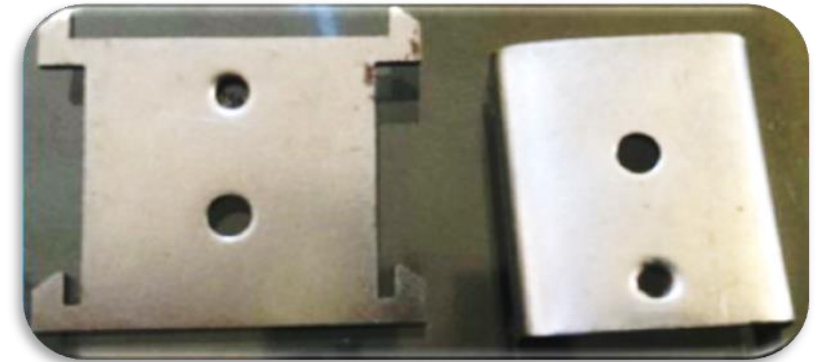

Placa metálica

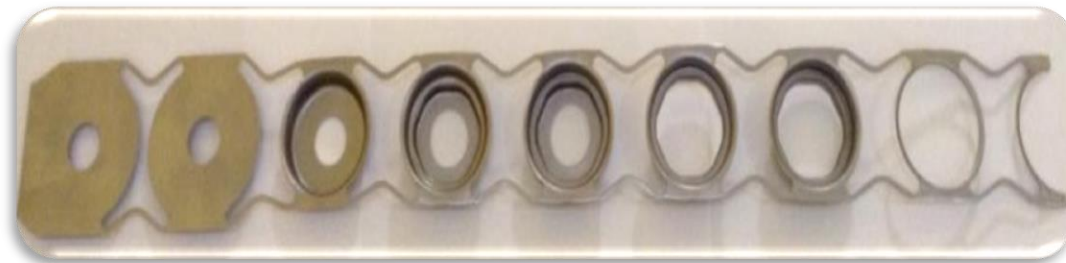

Desarrollo de tira progresiva

Maquinado de piezas en tornos automáticos

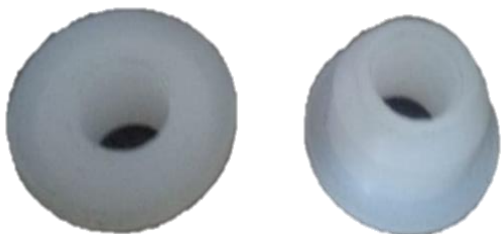

Buje



Perno



Buje de Trómel



Buchse



Perno



Anillos

Proyecto épsilon para cortinilla de quemacocos RT y Jetta A6 del año 2011-2017



Refuerzo Delantero Épsilon



JETTA A6

Tuerca A6



Ficha metálica para fijación de la
cortinilla del quema coco

Refuerzo Trasero Épsilon



Refuerzo RT



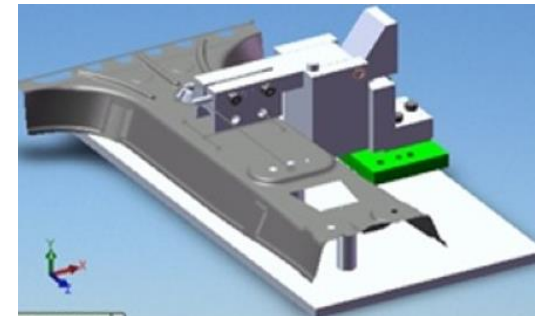
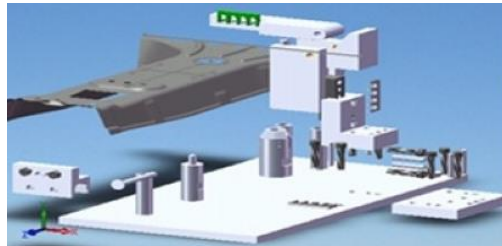
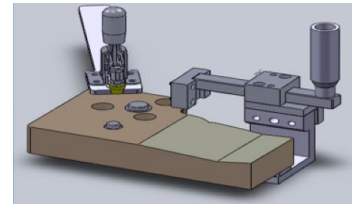
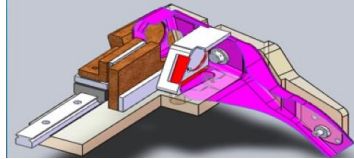

Diseño y fabricación de dispositivos de ensamble y control



TROQUELES Y MOLDES

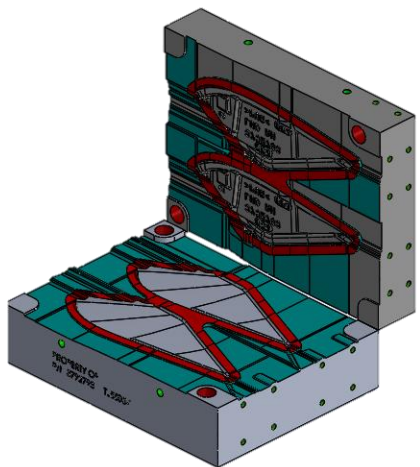

Molde
Cambio de ingeniería

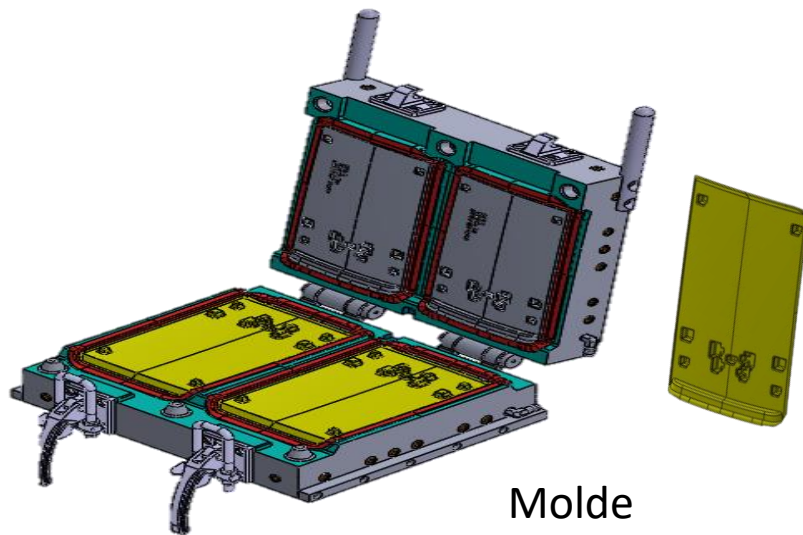
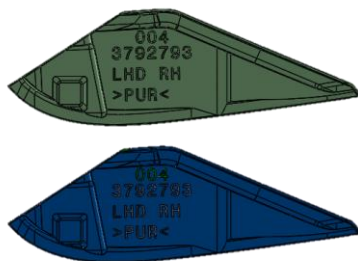

Molde

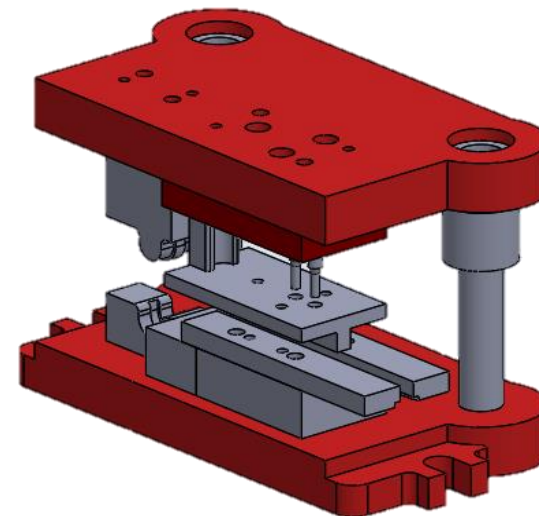

Troquel

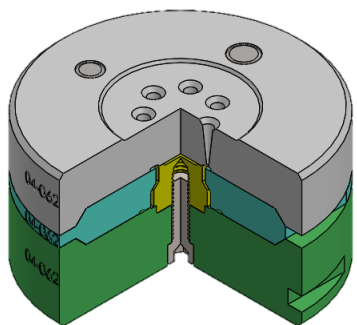

Molde de inyección
plástica

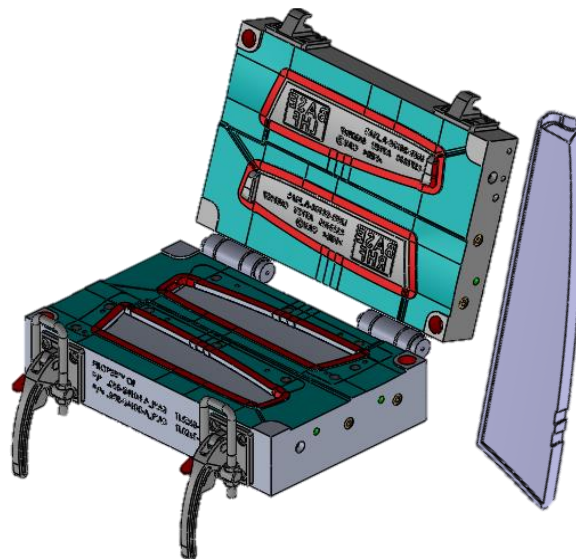
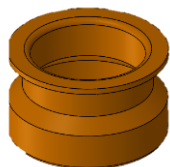

Molde de inyección de poliuretano

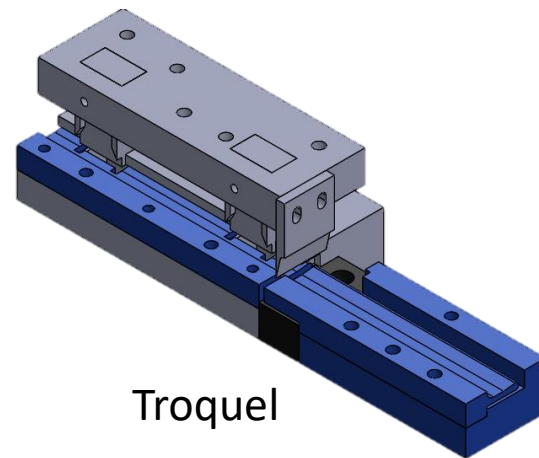

Troquel

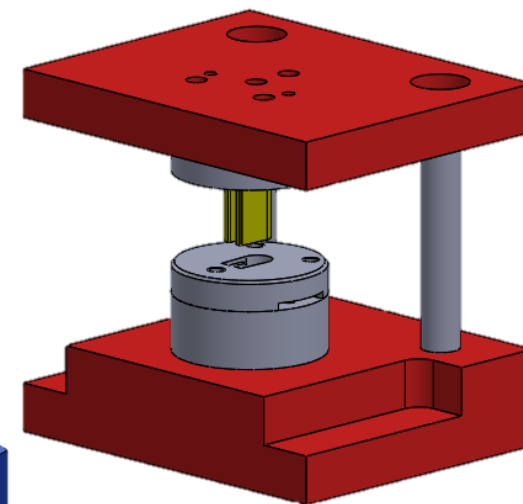

Troquel



Troquel Progresivo

Molde 1 Cavity

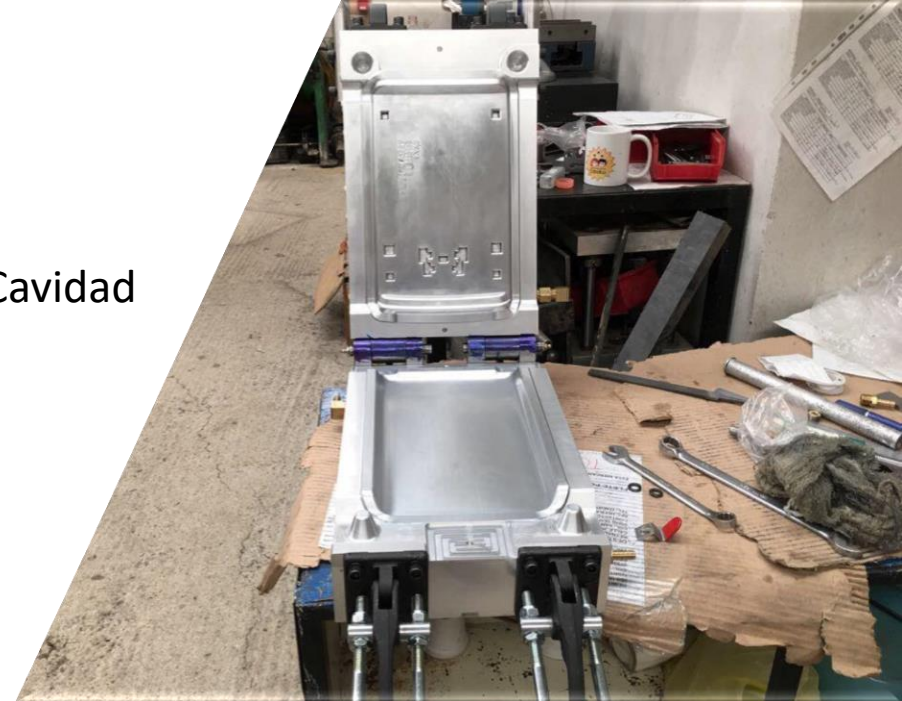

Molde Porta Gafas





Maquinaria

- 1 Centro de maquinado vertical CNC
- 2 Electroerosionadora de hilo
 - 1 Electroerosionadora de penetración
- 1 Torno CNC
 - 1 Torno CNC de herramientas vivas
- 3 Fresadora convencional
- 2 Torno convencional
- 2 Torno de levas traub
- 1 Dobladora
- 1 Taladro vertical
- 2 Rectificadora para superficies planas
- 1 Troqueladora de 50 toneladas
- 1 Troqueladora de 60 toneladas
- 1 Cizalla
- 1 Router CNC 4 ejes

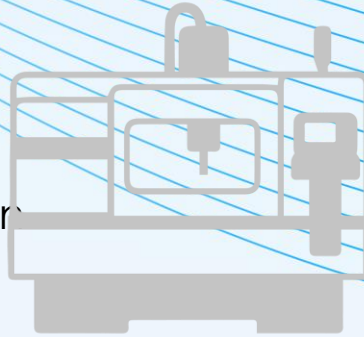



CONTACTO

Eder Uzziel Carmona Méndez



Cel. 241-419-4800

facturas.0819@gmail.com

/troquelesyherramientas